

# H-Track

## Electro-Hydraulic Linear Actuator

Installation Manual

Edition 2026-01



## Version history

<b>Edition</b>	<b>Reason for revision</b>
2019-11	First edition
2021-09	General update due to release of new catalog
2021-11	Update of the lead colors and the performance matrix
2024-02	B-metering removed
2025-06	IP68 version, new adapter, updated dimensions, performance and ordering key.
2026-01	Updated front and back cover logotypes and layout

## Warranty

The H-Track is warranted to be free from defects in materials and workmanship for a period of twelve (12) months from date of delivery. The application of this product is the responsibility of the buyer and Thomson makes no representation or warranty as to the suitability of the product for any particular use or purpose. For a copy of the entire warranty for this product that is contained in our standard terms and conditions of sale, please go to [http://www.thomsonlinear.com/website/com/eng/support/terms\\_and\\_conditions.php](http://www.thomsonlinear.com/website/com/eng/support/terms_and_conditions.php).

## Disclaimer

**Technical changes to improve the performance of the equipment may be made without prior notice!**

All rights reserved. No part of this work may be reproduced in any form (by printing, photocopying, microfilm or any other method) or processed, copied or distributed by electronic means without the written permission of Thomson.

Contents

- 1. General ..... 4**
  - 1.1 About this manual ..... 4
  - 1.2 Target group ..... 4
  - 1.3 Symbols used ..... 4
  - 1.4 Transport and storage ..... 4
  - 1.5 Packaging ..... 4
  - 1.6 Disposal ..... 4
  - 1.7 Support ..... 4
  
- 2. Safety ..... 5**
  - 2.1 Safety notes ..... 5
  
- 3. Standards ..... 5**
  - 3.1 EC Declaration of conformity ..... 5
  
- 4. Installation ..... 6**
  - 4.1 Product label ..... 6
  - 4.2 Terminology ..... 6
  - 4.3 Operation environment ..... 6
  - 4.4 Mechanical installation ..... 7
  - 4.5 Electrical installation ..... 10
  
- 5. Troubleshooting ..... 12**
  - 5.1 Troubleshooting ..... 12
  
- 6. Technical specifications ..... 13**
  - 6.1 Technical data ..... 13
  - 6.2 Weight ..... 14
  - 6.3 Performance matrix ..... 14
  - 6.4 Ordering key ..... 15
  - 6.5 Front and rear adapter center to center distance ..... 16

## 1. General

### 1.1 About this manual

This manual contains mechanical and electrical installation instructions for the H-Track electro-hydraulic linear actuator. It also contains, among other things:

- technical data
- installation data
- type designation key.

It is important to carefully read this manual before installing the actuator and to have the correct qualifications needed to perform the installation.

### 1.2 Target group

This manual addresses qualified mechanical and electrical personnel.

### 1.3 Symbols used



This symbol is shown to highlight a general warning, general instruction or as a warning for a mechanical hazard.

### 1.4 Transport and storage

The actuator may only be transported and stored in the original packaging supplied by Thomson. The temperature during transportation and storage must be between -26 to +65° C (-20 to +150° F). Avoid shocks to the package. If the package is damaged, check the actuator for visible damage and notify the carrier, and if appropriate also Thomson.

### 1.5 Packaging

The packaging consists of a cardboard box. The box contains the actuator and this manual. For large quantity orders, bulk packaging may be used in which case the packaging and the content will vary depending on the order agreement.

### 1.6 Disposal

Where required by law, used packaging and actuators are taken back by Thomson for professional disposal if the transportation cost is paid by the sender. Please contact Thomson for shipping information.

### 1.7 Support

If technical support or information is needed for this product, please contact the nearest Thomson Service Center. See the back of this manual. You can also visit [www.thomsonlinear.com](http://www.thomsonlinear.com) for information on this product and how to contact us.

## 2. Safety

### 2.1 Safety notes



- Only properly qualified personnel are permitted to perform mechanical and electrical installation of this product. Properly qualified personnel are familiar with mechanical or electrical installation work and have the appropriate qualifications for their job.
- Read this manual and any other available documentation before working on the equipment that the actuator is or shall be a part of.
- Conform strictly to the information contained in this manual and on the actuator product label on the actuator. Never exceed the performance limits stated herein.
- Never work on the actuator or its installation with the power on.
- Never unplug any cables or connectors during operation or with power on.
- Immediately stop using the actuator if it seems faulty or damaged in any way and notify an appropriate person so that corrective actions can be taken.
- Never open the actuator as that will compromise the sealing, the function of the actuator and allow hydraulic fluid to escape. There are no serviceable components inside.
- Collaring of hydraulic fluid on the piston rod is normal. Over the life of the product, drops may accumulate. Hydraulic fluid film should not be removed.

## 3. Standards

### 3.1 EC Declaration of incorporation of partly completed machinery

We, Thomson Linear, declare that this product corresponds with the International Standard ISO 13766:2006-05 2nd Edition (Earth Moving Machinery, Electromagnetic Compatibility). The directive (MD) 2006/42/EC annex 2.1.B, RoHSII directive 2011/65/EU, and that the standard EN ISO 12100:2010, Safety of machinery, have been applied.

<p><b>H-Track Actuator</b> ..... Product</p>	<p><b>Hxx-xx-xxxx-xxx</b> ..... Description</p>
--	---

Can be used when the machine or the system, which it shall be, a part of is in accordance with the demands in the EEC Machinery Directive and/or other relevant regulations.

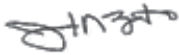
<p><b>08/06/2019</b> ..... Date</p>		
<p><b>Jared Zammuto</b> ..... Name</p>	<p><b>NPDT Manager</b> ..... Title</p>	<p> ..... Signature</p>

## 4. Installation

### 4.1 Product label

The product label can be found on the side of the reservoir tube. It will tell you which model of actuator you have, manufacturing date, country of origin; address of manufacturing location, phone contact number and traceable serial number with barcode. Please study the product label to determine actuator type before starting any installation or service on the actuator. If you need any assistance from Thomson, please provide the serial number, manufacturing date and the designation of the actuator(s) in question. You can also directly access H-Track information on [www.thomsonlinear.com](http://www.thomsonlinear.com).



### 4.2 Terminology

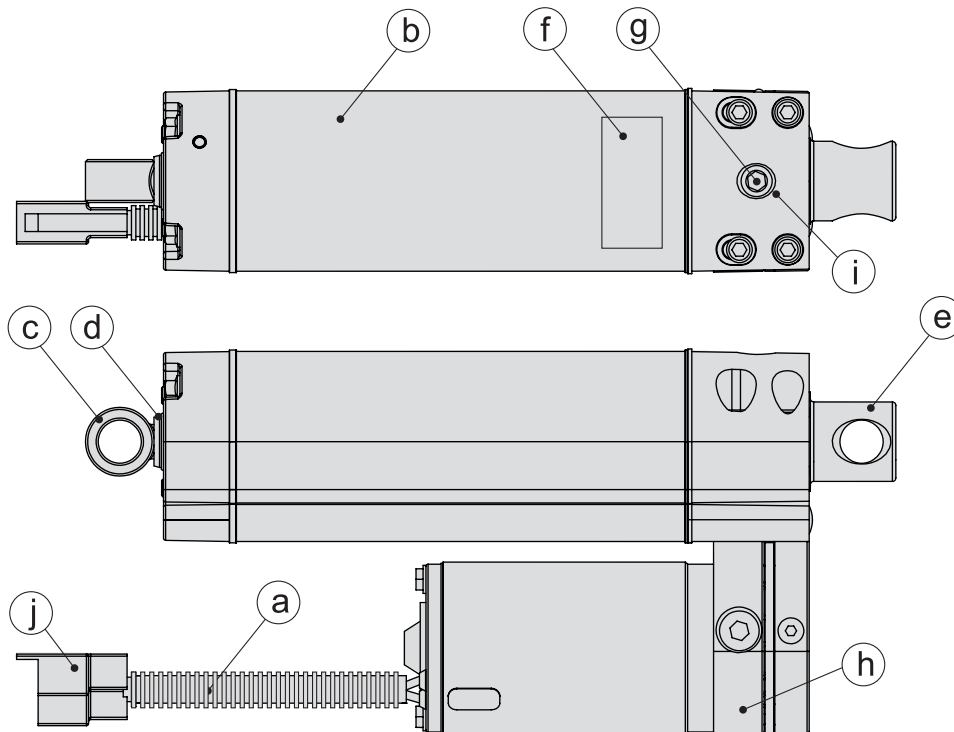

- |                            |   |                                   |               |
|----------------------------|---|-----------------------------------|---------------|
| a. motor wires in loom     | b. reservoir tube (tank)  | c. front adapter (standard shown) | d. piston rod |
| e. rear adapter            | f. product label  | g. manual release input           | h. pump       |
| i. plug for manual release | j. connector (shown) or ring terminals depending on motor model |                                   |               |

4.3 Operation environment



Min. -26° C (-20° F)



Max. +65° C (+150° F)



IP66 / IP69K or IP68

1. Operation temperature range is -26 to +65° Celsius (-20 to +150° Fahrenheit).
2. Protection degree against the ingress of water and particles is IP66 / IP69K or IP68 depending on the motor type. See section 6.4.
3. Relative humidity range is 10 - 90 % non-condensing.

4.4 Mechanical installation

4.4.1 General installation safety notes



- Never work on the actuator with the power switched on.
- Do not hold the piston rod while the unit is energized.
- Failure modes of the actuator should be considered to ensure it does not create harm.

4.4.2 Basic installation considerations

1. Only mount the actuator using the hole in the front adapter (section 4.2 (c)) and the rear adapter (e). There are four front adapter types - standard (hole), spherical joint, male thread or female thread.
2. Make sure that the actuator mounting position allows access to the motor wires (a), so that access is provided to connect/disconnect power.
3. The manual release (g) must have enough free space around it to allow it to be operated (section 4.4.6).
4. The front adapter (c) must be locked with anaerobic adhesive to prevent it from unthreading.

4.4.3 Load configuration installation considerations

The load configuration of an actuator is determined by studying the product label (section 4.1) and then looking the configuration up (C, H or N) in the ordering key (section 6.4). Make sure to install the actuator in accordance to its load configuration limitations.

C- = gravity does not affect the load in any direction.

H- = load is always acting to drive the piston rod into the actuator.

N- = load is always acting to draw the piston rod out of the actuator.

Horizontally supported load  
(case N)

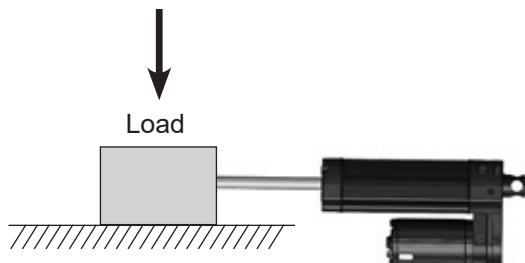

Compressing load  
(case C)

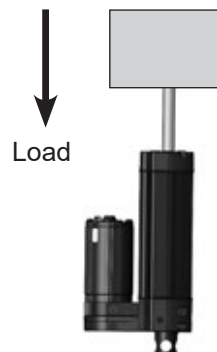

Extending load  
(case H)

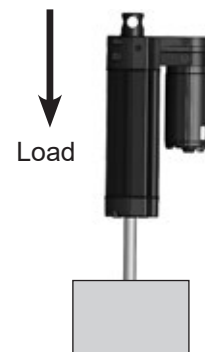

## 4.4.4 Mounting orientation and forces

Make sure the actuator load configuration (section 4.4.3) is taken into consideration and that there is enough space between the rear base end and any surrounding objects to allow the manual release to be accessed (section 4.4.5), before moving onto the next steps.

1. Only mount the actuator to the rear and front adapter mounting holes.
2. Always install actuator so that the force of the load acts in the center of the piston rod and the rear adapter (a).
3. Only use solid mounting pins and support them at both ends (b).
4. The mounting pins must be parallel to each other both radially and axially (c).
5. Do not attempt to mount the actuator at the tank tube (d).

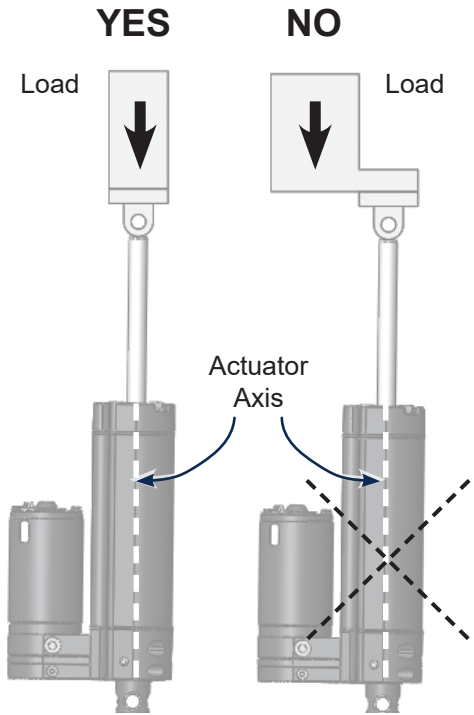

(a) Load must act in the piston rod center.

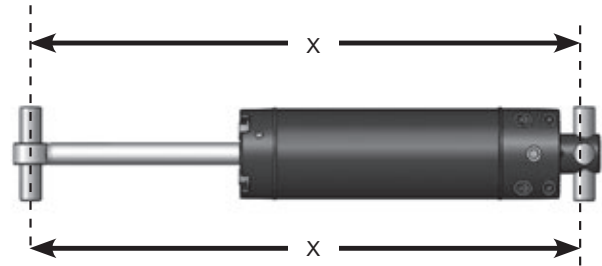

(c) Mounting pins must be parallel.

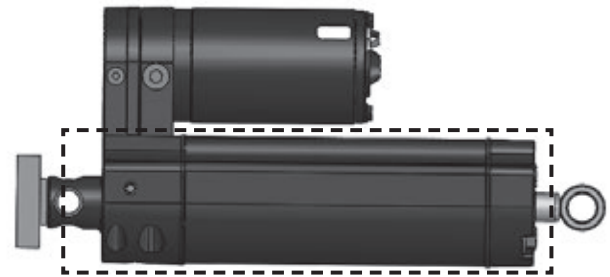

(d) Do not mount the actuator at the tank tube.

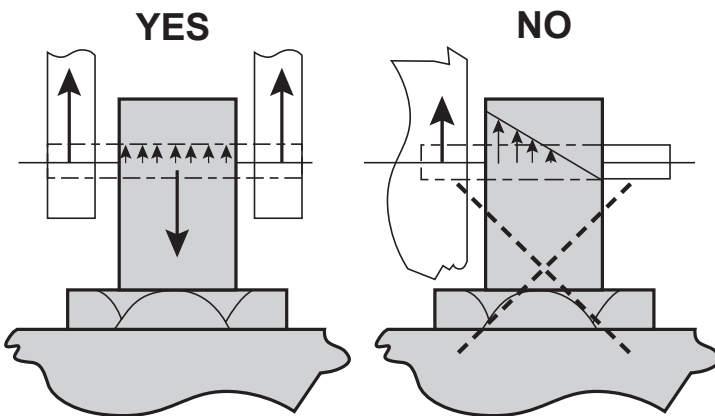

Mounting pins must be solid and supported at both ends (b).

#### 4.4.5 Manual release and operation

1. To operate the manual release, isolate the load from the actuator so piston rod is unloaded with less than 3 mm (0.13 inch) of movement.
2. Use a flat-head screwdriver (a) to pierce a hole in the plug and pry cap free to get access to the manual release input (b).
3. Rotate manual release  $\frac{1}{4}$  turn at a time counter-clockwise (left) using a  $\frac{1}{4}$  inch hexagon key (c). Carefully observe the unit after each  $\frac{1}{4}$  turn (left) for piston rod movement. Once the piston rod begins to move, wait for the actuator to be completely unloaded.
4. Once the unit is unloaded and the load is safe, the actuator can be removed from service.
5. Do not reinstall the actuator after engaging the manual release.



Never use any type of drill or power tool to operate the manual release.



(a) Flat-head screwdriver



(b) Manual release input



(c)  $\frac{1}{4}$  inch hexagon key

### 4.5 Electrical installation and operation

#### 4.5.1 General notes



- Make sure the leads leading to the motor can handle the maximum motor current.
- An emergency stop is recommended to reduce the chance of a crushing hazard.
- Never work on the actuator or the wiring with the power switched on.

#### 4.5.2 Fuse size

Protect the actuator and the wiring by using a slow blow fuse between the actuator and the power source.

Recommended fuse size		
Actuator supply voltage	Fuse size	
	Motor type 1 and 3	Motor type 2
12 Vdc	50 A	100 A
24 Vdc	20 A	40 A

#### 4.5.3 Motor wire connections

The actuator is always supplied with two power wires. In the end of the wires, there is depending on the motor type one the following per the table below. Mating connector is not included.

Motor wire connections		
Motor type	Connector on the actuator motor wires	Mating connector
1	Packard 56 series connector 2984883 male body + 2971962 terminals (2×)	Packard 56 series connector 2973781 female body + 2973782 terminals (2×)
2	no connector (0.25 inch ring terminals)	-
3	Metri-pack 280 connector 15300002 male housing + 12048159 terminals (2×) + 15300014 TPA + 15324980 wire seals (2×)	Metri-pack 280 connector 15300027 female housing + 12129493 terminals (2×) + 15300037 TPA + 15324980 wire seal (2×)

#### 4.5.4 Lead cross sections

To avoid malfunction due to voltage drop, the cross section of the leads between the actuator power cable leads and the power source must be of sufficient size. Calculations based on the supply voltage, the current draw, the length of the cables, the ambient temperature and the local regulations must be done.

#### 4.5.5 Electrical connection

- F Fuse
- S1 Double pole double throw switch

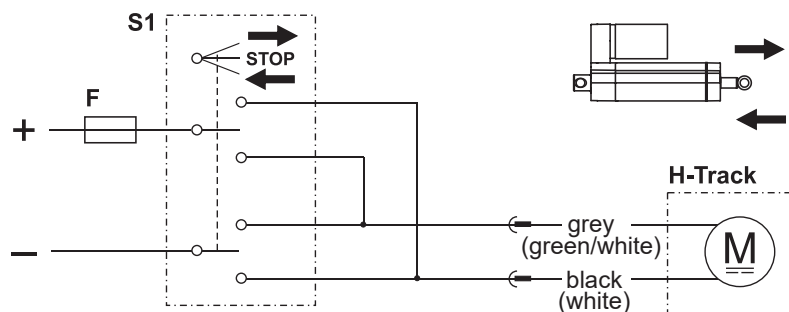

To extend the actuator, apply +Vdc to black (white) and -Vdc to grey (green/white). To retract, apply -Vdc to black (white) and +Vdc to grey (green/white). Colors in between brackets are valid for motor type 2. Avoid running the actuator in to the ends.



Always turn power off to the actuator before working on it.

#### **4.5.6 Motor thermal switch**

The motor is equipped with a bi-metal thermal switch, which will trip and stop the motor in case of overheating. The switch will reset automatically once the motor has cooled down. Always investigate and, if necessary, correct the cause(s) of a trip before taking the actuator into operation again.

#### **4.5.7 Current draw and power supply dimensioning**

The current draw of an H-Track may seem counter-intuitive when measured since it is not always linear to the load, and depends on and varies with the load configuration, direction of travel, ambient temperature, internal actuator temperature, etc. The max. and min. current draw stated for each actuator (see section 6.3.1) is the highest and lowest current draw you can expect during operation irrespective of the load in question, and is what the power supply must be dimensioned for. The load configuration of the actuator (also see section 4.4.3) will however in general influence the current draw as described below.

##### Configuration N

- Current draws are at maximum extending or retracting when the resisting load are at its maximum.

##### Configuration C

- Current draws are at maximum while extending when the opposing load is at maximum.
- The current draw is between maximum and minimum while retracting a load.
- The current draw can be near the stated maximum value when retracting with no load.

##### Configuration H

- Current draws are at maximum while retracting when the opposing load is at maximum.
- Current draw is between maximum and minimum while extending a helping-load.
- Current draw can be near the stated maximum value when extending with no load.

## 5. Troubleshooting

### 5.1 Troubleshooting

Troubleshooting list		
Issue	Problem	Solution
Actuator does not move, makes no sound.	Actuator is not receiving proper input voltage.	Ensure the actuator is being supplied with proper rated input voltage.
Actuator makes buzzing sound, does not move.	Actuator does not have enough power and is stalled.	Ensure your power supply can provide enough current to move the rated load.
Actuator moves slower/faster than expected.	Actuator is receiving too low/ too high input voltage.	Ensure that actuator is provided with proper nominal input voltage amount (i.e. 12 Vdc for a 12 Vdc rated actuator).
The actuator, when powered, is causing the fuse to blow.	Fuse is not rated for current draw of the actuator.	Make sure that the fuse is rated for the in-rush current of the actuator, which is typically 1.5 times the rated current draw of the actuator at full load. Slow-blow fuses are also recommended.
The actuator stops during motion but can, after a while, be operated again	The thermal switch in the motor has tripped due to an overload/overheating condition, disconnecting the actuator motor until the switch has cooled down and resets automatically.	Make sure the combination of load, duty cycle and/or ambient temperature is within the permissible limits and that there are no problems with any related mechanical linkage, forcing the actuator to work harder than expected. Possible solutions include reducing the load and/or duty cycle, lowering the ambient temperature and using forced cooling
The actuator is not stopping at the right place.	Actuator is coasting due to helping load/lack of dynamic braking.	Consider shorting the motor leads together when stopping the actuator to dynamically brake the motor, especially in circumstances where the load applied would "help" move the piston rod.
Actuator motor is spinning but piston rod is not moving.	The actuator has encountered impact load that has caused a vacuum imposed on the fluid and created air bubbles.	Allow actuator to rest in piston rod up position for air to migrate back to the reservoir. If actuator does not return to normal state, the actuator will need to be analyzed as an RMA (Return Material Authorization) at the manufacturing facility.
The actuator is leaking more than rod collaring.	The actuator has become damaged.	Actuator will need to be analyzed as an RMA (Return Material Authorization) at the manufacturing facility.
The actuator drifts over time exceeding 0.008 inch linear travel per hour.	The actuator relief valves are leaking. It is normal for the actuator to drift 0.008 inch linear travel per hour while loaded. Similar to a traditional hydraulic system.	Actuator will need to be analyzed as an RMA (Return Material Authorization) at the manufacturing facility.

## 6. Technical specifications

### 6.1 Technical data

Technical specification	H-Track	
Input voltages [Vdc]	12	24
Input voltage tolerance [Vdc]	9 - 16	18 - 32
Stroke length [in]	see model number on product label and consult ordering key	
Static load (Fx), ends of stroke, maximum <sup>(1)</sup> [N (lbf)]	22241 (5000)	
Static load (Fx), mid stroke, maximum <sup>(1)</sup>	1.25 × maximum dynamic load	
Dynamic load (Fx), maximum [lbf]	see model number on product label and consult ordering key	
Speed @t no load / max. load <sup>(2)</sup> [in/s]	see model number on product label, consult ordering key and appropriate load chart	
Current draw @ rated max. load [A]	see model number on product label, consult ordering key and the power supply chart	
Weight [lb]	see table section 6.2	
End play, maximum [mm (in)]	0.4 (0.015)	
Operating temperature limits, standard units <sup>(3)</sup> [°C (°F)]	- 26 to + 85 (- 20 to + 150)	
Full load duty cycle [%]	25	
Restraining torque [Nm (lbf-in)]	0.1 (0.89)	
Motor leads cross section [mm <sup>2</sup> (AWG)]	Motor type 1 and 3 2.0 (14) Motor type 2 3.0 (12)	
Motor leads length (depending on option) [mm (in)]	254 ± 25 (10 ± 1)	
Motor leads termination type Motor type 1 Motor type 2 Motor type 3	Packard 56 series connector ring terminals Metri-pack 280 series connector	
Protection class - static (dynamic) Motor type 1 and 2 Motor type 3 <sup>(4)</sup>	IP67 / IP69K (IP66) IP68 (IP68)	
Salt spray resistance <sup>(5)</sup> [h]	2000	
Safety features Pressure relief valve extend Pressure relief valve retract Motor bi-metal thermal switch	yes yes yes	
Compliances	CE, RoHS, Prop65, Reach	

(1) When fully retracted/extended, the actuator can be subjected to an extending/compressing static load up to 22241 N (5000 lbf). Loads acting in the opposite direction or anywhere near mid-stroke can only be 1.25 × maximum dynamic load before the actuator starts to drift.

(2) Speeds vary depending on load.

(3) H-Track can withstand air temperatures below the freezing point but must be protected from freezing while submerged in water.

(4) Tested for 650 hours of submerged operation up to a depth of 2 meters (79 in) at rated duty cycle.

(5) Tested per ASTM B117 (salt fog exposure for a duration of 2000 hours).

## 6.2 Weight

Weight [lb (kg)]						
Designation	Stroke					
	2	4	6	8	10	12
H2x-xx-1	6.9 (3.1)	7.8 (3.5)	8.7 (3.9)	9.6 (4.4)	10.5 (4.8)	11.4 (5.2)
H3x-xx-1	7.1 (3.2)	8.2 (3.7)	9.3 (4.2)	10.4 (4.7)	11.5 (5.2)	12.6 (5.7)
H2x-xx-2	8.5 (3.9)	9.4 (4.3)	10.3 (4.7)	11.2 (5.1)	12.1 (5.5)	13.0 (5.9)
H3x-xx-2	8.7 (3.9)	9.8 (4.4)	10.9 (4.9)	12.0 (5.4)	13.1 (5.9)	14.2 (6.4)
H2x-xx-3	9.3 (4.2)	10.2 (4.6)	11.1 (5.0)	12.0 (5.4)	12.9 (5.8)	13.9 (6.3)
H3x-xx-3	9.5 (4.3)	10.6 (4.8)	11.7 (5.3)	12.8 (5.8)	13.9 (6.3)	15.0 (6.8)

## 6.3 Performance matrix

### 6.3.1 Performance matrix

Consult the product label for information on the actuator model number. Next consult the ordering key and look up the load and speed for your actuator in the matrix below.

Performance matrix <sup>(1)</sup>										
Model	Max. Dynamic Load [lbf (N)]		Extend Speed [in/s (mm/s)]		Retract Speed [in/s (mm/s)]		Current Draw [A] <sup>(2)</sup>			
	Extending	Retracting	@ No. Load	@ Max. Load	@ No. Load	@ Max. Load	12 Vdc Input Voltage		24 Vdc Input Voltage	
							Max.	Min.	Max.	Min.
Motor Type 1 (standard 2.5 inch diameter motor)										
H2x-xx-1B42	950	750	1.90	0.53	2.29	0.64	42	8	22	5
H3x-xx-1B43	1100	825	1.60	0.47	2.00	0.59	42	8	22	5
H2x-xx-1B22	1400	1100	1.20	0.34	1.45	0.41	42	8	22	5
H3x-xx-1B23	1750	1300	1.00	0.29	1.25	0.36	42	8	22	5
H2x-xx-1B02	2400	1750	0.50	0.15	0.60	0.18	42	8	22	5
H3x-xx-1B03	3200	2400	0.45	0.13	0.56	0.16	42	8	22	5
Motor Type 2 (standard 3 inch diameter motor)										
H2x-xx-2B42	1425	1131	1.90	0.53	2.29	0.64	80	14	43	10
H3x-xx-2B43	1650	1238	1.60	0.47	2.00	0.59	80	14	43	10
H2x-xx-2B22	2100	1666	1.20	0.34	1.45	0.41	80	14	43	10
H3x-xx-2B23	2625	1969	1.00	0.29	1.25	0.36	80	14	43	10
H2x-xx-2B02	3750	2975	0.50	0.15	0.60	0.18	80	14	43	10
H3x-xx-2B03	4800	3600	0.45	0.13	0.56	0.16	80	14	43	10
Motor Type 3 (3 inch marine grade motor)										
H2x-12-3B42	1425	625	1.25	0.35	1.51	0.42	30	4	-	-
H3x-12-3B43	1650	684	1.05	0.31	1.32	0.39	30	4	-	-
H2x-12-3B22	2100	920	0.90	0.26	1.09	0.31	30	4	-	-
H3x-12-3B23	2625	1088	0.75	0.22	0.94	0.27	30	4	-	-
H2x-12-3B02	3750	1450	0.65	0.31	0.81	0.38	30	4	-	-
H3x-12-3B03	4800	1675	0.55	0.26	0.71	0.34	30	4	-	-

1) The table above is valid for the temperature span of 40 – 120°F (4 – 50°C). H-Track can operate in the larger range of -20 – 150°F (-26 – 65°C), but at temperatures below 40°F (4°C), force and current begin to increase, while speed decreases. At temperatures above 120°F (50°C), speed will decrease slightly. The exact amount of performance change is difficult to calculate. Also, when it comes to the lower temperature span, the performance will move towards what is stated above as the temperature rises in the actuator due to the heat generated by its work. Please consult Thomson customer service for more information.

2) The current draw is not linear to the load but depends on and varies with the load configuration, direction of travel, ambient temperature, internal actuator temperature, and can not be easily determined for a specific situation. The above given max. and min. current draw is the highest respectively the lowest current draw you can expect during operation, and is what the power supply must be dimensioned for. Please consult Thomson customer service for more information.

## 6.4 Ordering key

Ordering key									
Position	1	2	3	4	5	6	7	8	9
Example	<b>H2</b>	<b>C-</b>	<b>12-</b>	<b>1</b>	<b>B0</b>	<b>2</b>	<b>-A</b>	<b>06</b>	<b>R90</b>
<p>1. Bore size H2 = 1.375 in H3 = 1.500 in</p> <p>2. Load configuration N- = the piston rod is not influenced by external loading, with no external force driving it in or out of the actuator C- = external loading exerts a continuous force, driving the piston rod into the actuator H- = external loading exerts a continuous force, drawing the piston rod out of the actuator</p> <p>3. Supply voltage 12- = 12 Vdc 24- = 24 Vdc</p> <p>4. Motor type 1 = 2.5 inch diameter, standard IP67/IP69K 2 = 3.0 inch diameter, standard IP67/IP69K 3 = 3.0 inch diameter, marine grade IP68 option</p> <p>5. Pump size B0 = 0.012 in<sup>3</sup>/rev B2 = 0.025 in<sup>3</sup>/rev B4 = 0.040 in<sup>3</sup>/rev</p>					<p>6. Piston diameter 2 = 0.625 in (default for H2 bore size) 3 = 0.750 in (default for H3 bore size)</p> <p>7. Adapter type -A = standard -B = spherical -D = female thread -E = cross hole *</p> <p>8. Stroke length 02 = 2 in (50 mm) 04 = 4 in (100 mm) 06 = 6 in (150 mm) 08 = 8 in (200 mm) 10 = 10 in (254 mm) 12 = 12 in (300 mm)</p> <p>9. Mount Blank = standard R90 = 90° position</p> <p>* Cross hole not available with bore size H2 or motor type 2</p>				

## 6.5 Front and rear adapters center to center distance

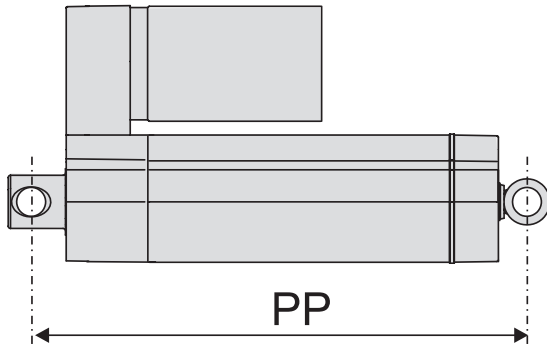

Front and rear adapters center to center distance at fully retracted (PP)																
Stroke Length [in (mm)]	Adapter type / Bore size															
	Adapter "A"				Adapter "B"				Adapter "D"				Adapter "E"			
	H2		H3		H2		H3		H2		H3		H2		H3	
	[in]	[mm]	[in]	[mm]	[in]	[mm]	[in]	[mm]	[in]	[mm]	[in]	[mm]	[in]	[mm]	[in]	[mm]
2 (50)	6.8	173	6.8	173	7.4	191	7.7	196	6.2	157	6.2	157	-	-	6.7	171
4 (100)	8.8	224	8.8	224	9.5	242	9.7	247	8.2	208	8.2	208	-	-	8.7	222
6 (150)	10.8	274	10.8	274	11.5	293	11.7	298	10.2	259	10.2	259	-	-	10.7	272
8 (200)	12.8	325	12.8	325	13.5	344	13.7	349	12.2	310	12.2	310	-	-	12.7	323
10 (254)	14.8	376	14.8	376	15.5	395	15.7	400	14.2	361	14.2	361	-	-	14.7	374
12 (300)	16.8	427	16.8	427	17.5	445	17.7	450	16.2	411	16.2	411	-	-	16.7	425



Contact us or any of our 2000+ global distribution partners by scanning the code below  
or visiting [www.thomsonlinear.com/contact](http://www.thomsonlinear.com/contact)



**RegalRexnord™**

[www.regalrexnord.com](http://www.regalrexnord.com)

[www.thomsonlinear.com](http://www.thomsonlinear.com)

H-Track\_Installation\_Operation\_MNEN-0008-05 | 20260122KB  
Specifications are subject to change without notice. It is the responsibility of the product user to determine the suitability of this product for a specific application. All trademarks property of their respective owners. ©2026 Thomson Industries, Inc. | 2400 Curtiss Street, Downers Grove, IL 60515 USA

**THOMSON®**